



### Our Mission

The mission of CWS is to provide Pure, Clean, Safe Water. Our systems capture and store rain, mains or well water in stainless steel large volume tanks attractively designed for the urban landscape. All systems remove disease and cancer-causing compounds from every shower, sink, and tap in your home.

**California Water Solutions**  
Mill Valley, California, 94941

415.524.8663  
cws@purerrainstorage.com  
purerrainstorage.com

♻️ *Printed on recycled paper.*

C O N S E R V A T I O N



CWS

California Water Solutions

## When it Rains it Stores™

- ◆ 10% Annual Water Savings \*
- ◆ 120 Tanks of Water per Year is an Average Family's Annual Water Demand
- ◆ Reduced Need for Bottled Water
- ◆ Reduced Plastic Waste Fewer Bottles Returned to Landfills
- ◆ 10 Installed Systems Return to the Aquifer **One Family's Annual Water Demand**

*\*12 Tanks Of Rain (10%) Is Captured In A 23" Annual Rainfall Region*

# How it works

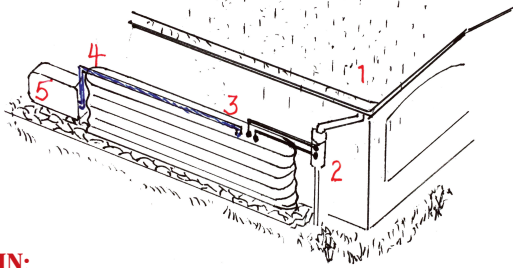

**RAIN:**

- 1 Rain Collected from Minimal 1,000 sf Roof Area
- 2 Rain Pre-filtered by Diverter/Filter in Downspout
- 3 Rain Fills Tank
- 4 Rain Pumped into Filtration Unit for Three-Stage Processing
- 5 Ultra-Filtered Water Directed into Home

**NO RAIN:**

- 3 (see below) Municipal Water Directed into Tank
- 4 and 5 (see below) Controller and Solenoid Direct Water into Tank to Maintain "Tank Full" Condition Year-Round

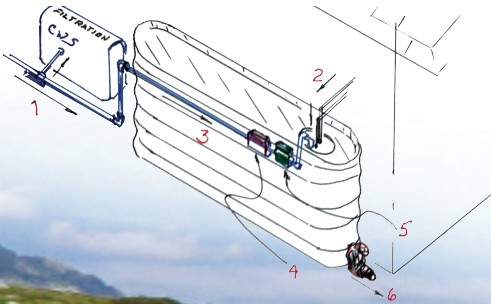

CWS

California Water Solutions

## Advantages

- ◆ Large-Volume Rain Water Catchment  
Minimum Volume is 1,300 Gallons  
Up to 2,500 Gallons \*
- ◆ Attractive "Thinline™" Shape  
Designed for the Urban Landscape
- ◆ From 5%-15% Annual Water Savings \*\*
- ◆ Rain Made Potable
- ◆ One Ultra-Filtered Rain-Filled Tank  
Equals 10,478 Seventeen Ounce  
Water Bottles

*\* 120 Tanks Of Water Per Year (1,322 Gallon Tank) Is An Average Family's Water Demand*

*\*\* 12 Tanks Of Rain Are Captured During A 22" Rainfall Year*





### **Our Mission**

The mission of CWS is to provide Pure, Clean, Safe Water. Our systems capture and store rain, mains or well water in stainless steel large volume tanks attractively designed for the urban landscape. All systems remove disease and cancer-causing compounds from every shower, sink, and tap in your home.

**California Water Solutions**  
Mill Valley, California, 94941

415.524.8663  
cws@purerrainstorage.com  
purerrainstorage.com

♻️ *Printed on recycled paper.*



**CWS**

**California Water Solutions**

## **Where There's Smoke There's Fire - Insurance™**

- ◆ **Defensible Space 100 Feet?**  
More! Your Entire Home and Property
- ◆ **NFPA-Rated Fire Valves and Hoses**
- ◆ **Year-round 1,500 Gallons**  
for Landscaping, Fire, or  
Drought Emergencies
- ◆ **Enhanced Property Value**  
Affordable Home Insurance  
Policies

**I N S U R A N C E**



CWS

California Water Solutions

## How it works

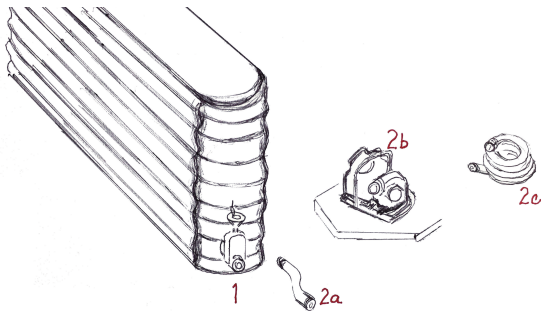

- 1** Kochek Fire Hose Valve
- 2a** Stiffener Hose
- 2b** Standard Fire Pump (100 psi max)
- 2c** Standard 2" Fire Hose (300 feet of Hose Recommended)
- 3** Pump Pressure Provides 30-50 gallons/minute of Water to Entire Structure and 100 feet of Defensible Space

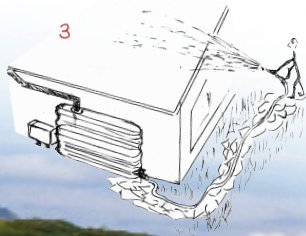

CWS

California Water Solutions

## Advantages:

- ◆ **Immediate and Reliable Property Defense**
- ◆ **25-50-85\***
- ◆ **Most Residential Structure Fires Begin from Ember Attack and Ember Ignition Well Ahead of the Fire Front**
- ◆ **Rain Made Potable**
- ◆ **1,000-1,200 Gallons of Water Hosed Onto the Home Creates a High Humidity Vapor Barrier. Fire Avoids Vapor Barrier.**

*\*25 Minutes At 50 Gpm If 1,500 Gal Tank 85% Full @ 100 Psi Max. Thirty Minutes If Tank 100% Full*





### Our Mission

The mission of CWS is to provide Pure, Clean, Safe Water. Our systems capture and store rain, mains or well water in stainless steel large volume tanks attractively designed for the urban landscape. All systems remove disease and cancer-causing compounds from every shower, sink, and tap in your home.

**California Water Solutions**  
Mill Valley, California, 94941

415.524.8663  
cws@purerrainstorage.com  
purerrainstorage.com

♻️ *Printed on recycled paper.*



CWS

California Water Solutions

## Healthy Bodies - Clean Water™

- ◆ **Three Stage Sub-Micron Filtration \***
- ◆ **Competitive with Reverse Osmosis Systems With No Wasted Water**
- ◆ **UV Third Stage Filtration to Eliminate Pathogens**
- ◆ **Whole-House Flow Rates Sufficient for Peak Water Demands \*\***

*\*5 Micron Stage I, Sub-Micron Stage II, UV Stage III*

*\*\*All Well, or Municipal, Or Rain Water is Filtered*

F I L T R A T I O N



CWS

California Water Solutions

## How it works

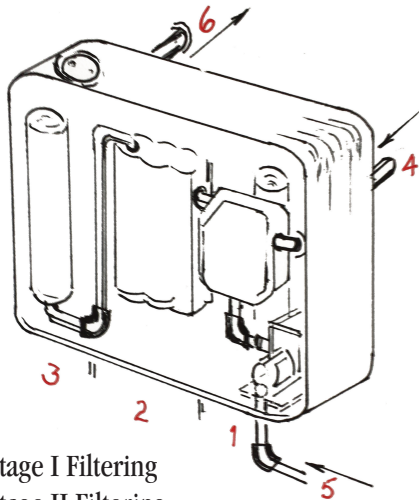

- 1 Stage I Filtering
- 2 Stage II Filtering
- 3 Stage III Filtering
- 4 Water in (*Municipal*)
- 5 Water in (*Tank*)
- 6 Finished Water into Home or Other Building



CWS

California Water Solutions

## Advantages

- ◆ Unlike RO Systems Which Waste Up To 9,000 Gallons Annually, **RCS Filtering Wastes No Water**
- ◆ **Point of Entry Ensures Pure, Clean, Safe Water** at Every Tap
- ◆ Volatile **Organic-Free** and **Chlorine-Free Showers**
- ◆ **5-7 Gallon per Minute** Surface Loading
- ◆ **No Aquaplate® Powder Coatings.** Water Contacts Only Stainless Steel

